

Ames 埃姆斯双移门淋浴房 (1.4m-1.6m)

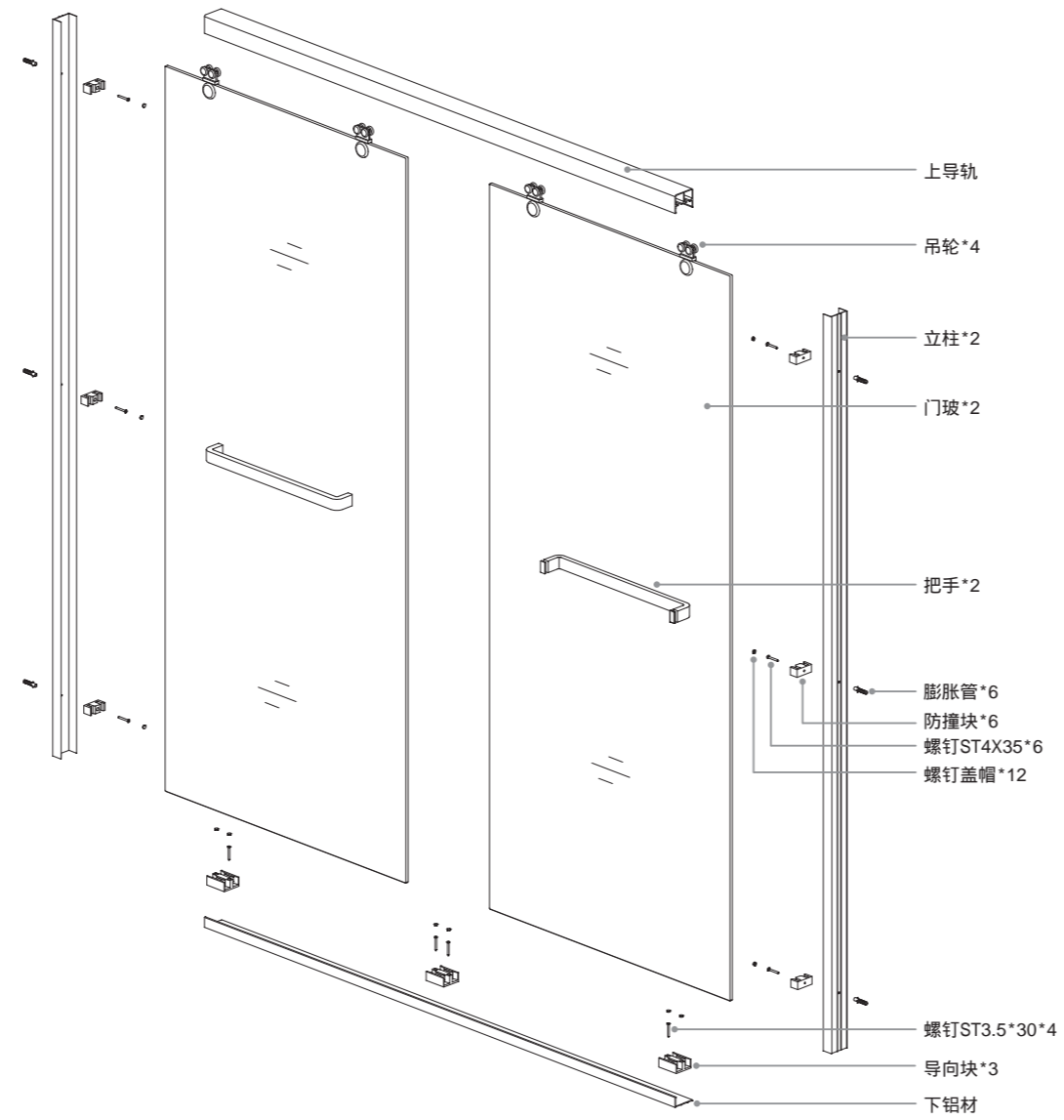

**SOLUX**

安装攻略

A911

Ames 埃姆斯双移门淋浴房 (1.6m-1.8m)

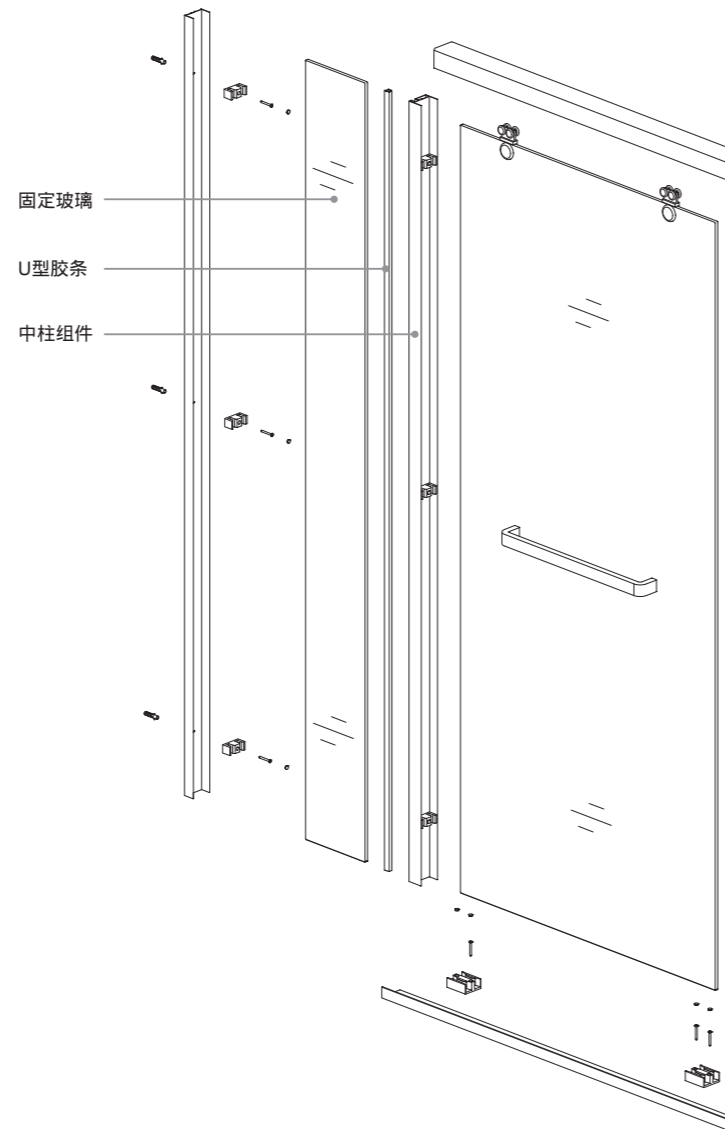

A912

13 安装完毕

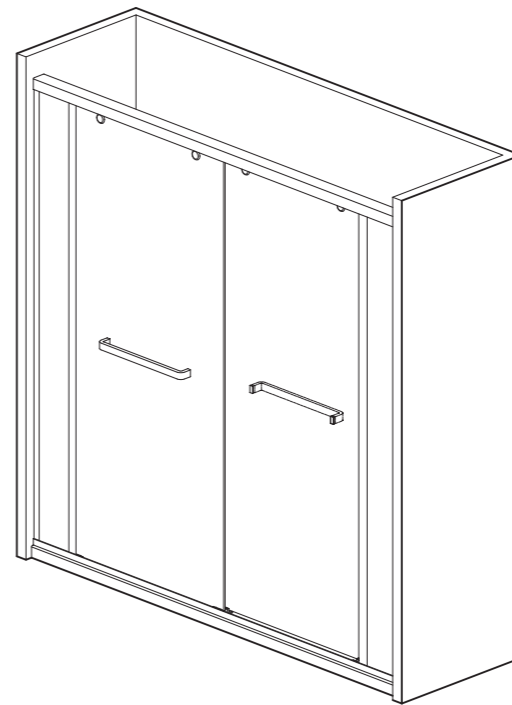

# 12 打胶

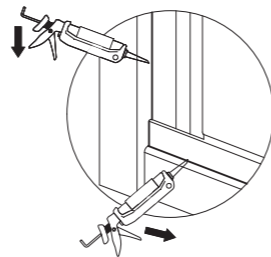
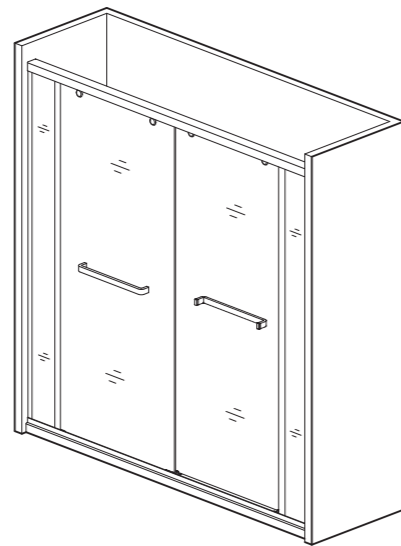

① 左右立柱和下铝材打胶

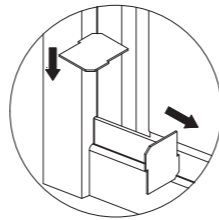

② 左右立柱和下铝材刮胶

将打玻璃胶的位置擦拭干净并保持干燥  
(注意打胶的位置不能是潮湿的)

注意：打完玻璃胶要 24 小时后才能使用。

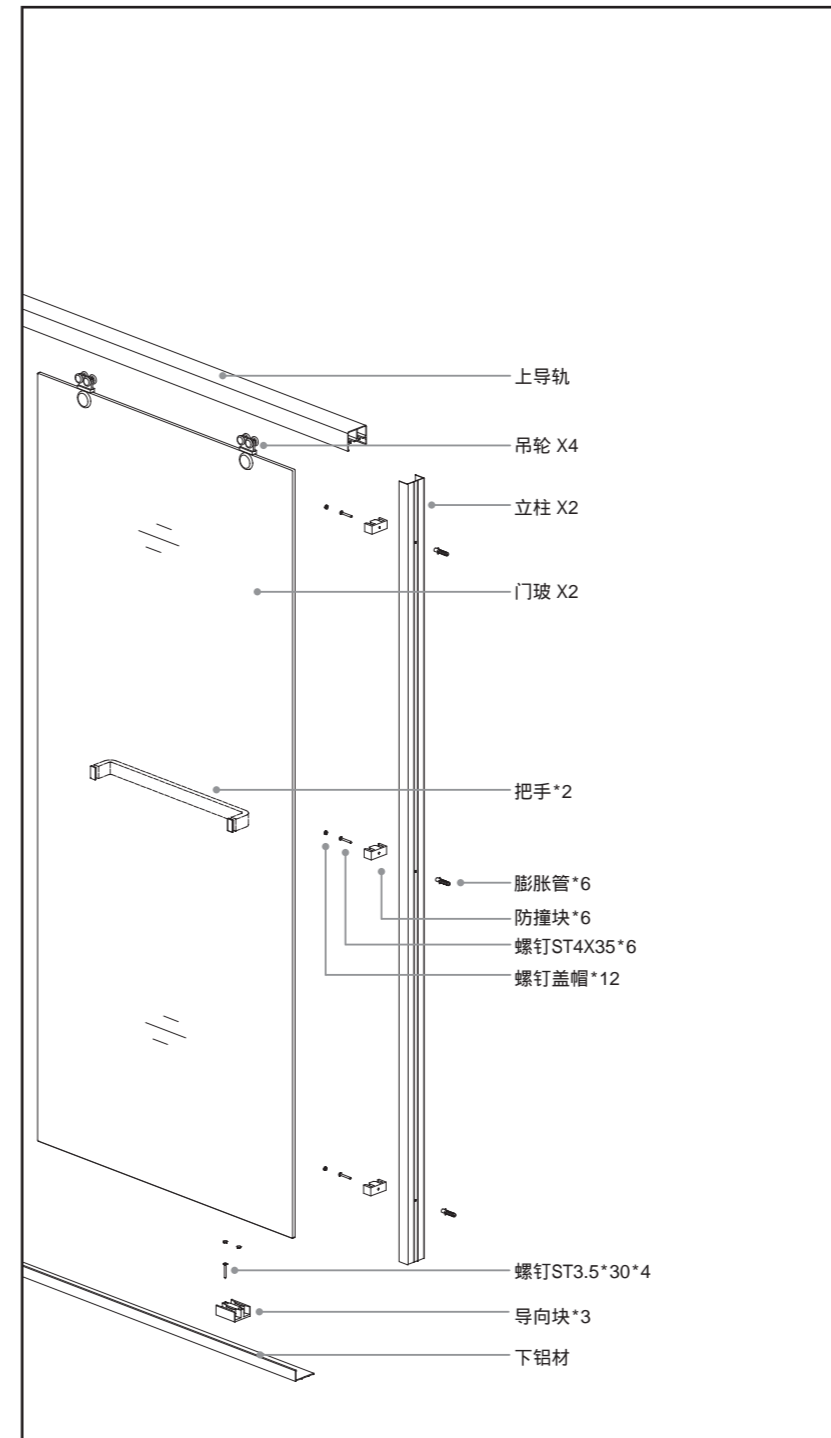

## Ames 埃姆斯双移门淋浴房 (1.8m-2.0m)

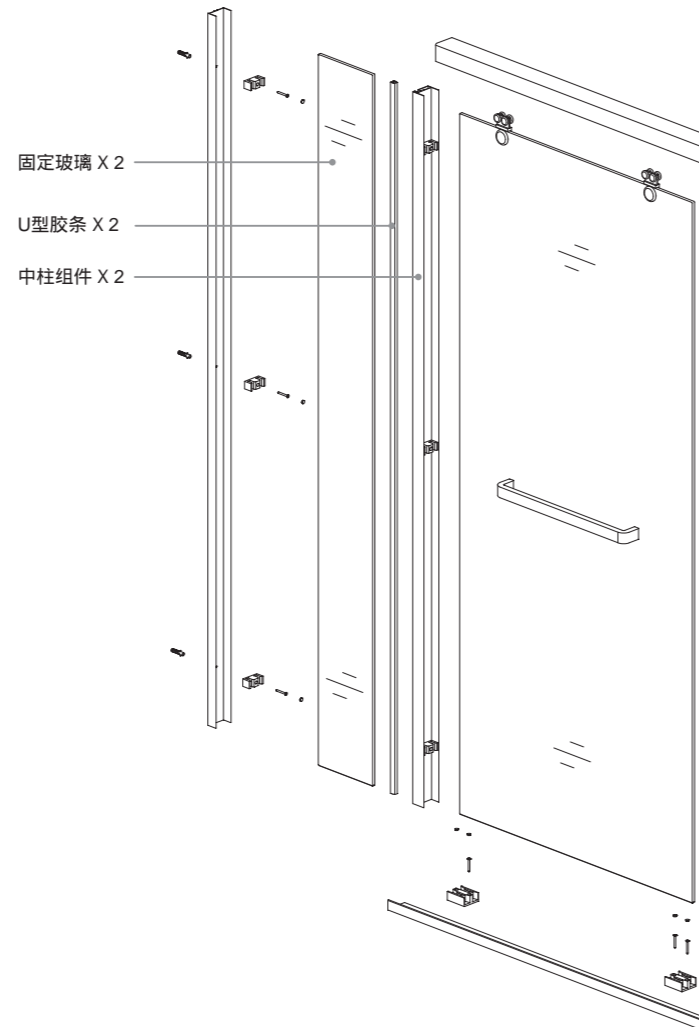

A913

## 11 调节门玻

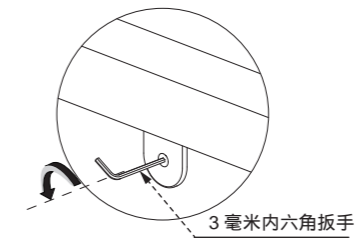
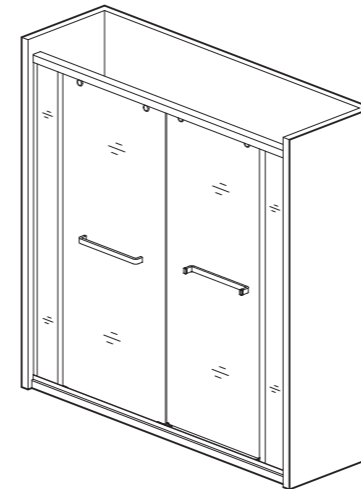

① 将吊轮的螺钉旋松

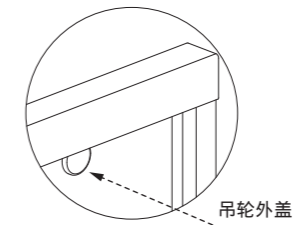

② 旋转吊轮的外盖, 使得玻璃能够卡进防撞块里面

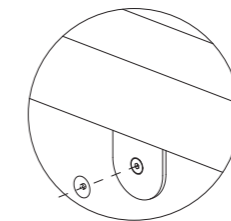

③ 锁紧吊轮的螺钉, 并装上螺钉装饰盖

关闭门玻, 查看门玻是否能够卡进防撞块里面。如果没有, 请调节两个吊轮。

注意: 由于墙壁有斜度玻璃不可能全部卡进防撞块里面, 保证超过一半就行。

# 10

安装把手

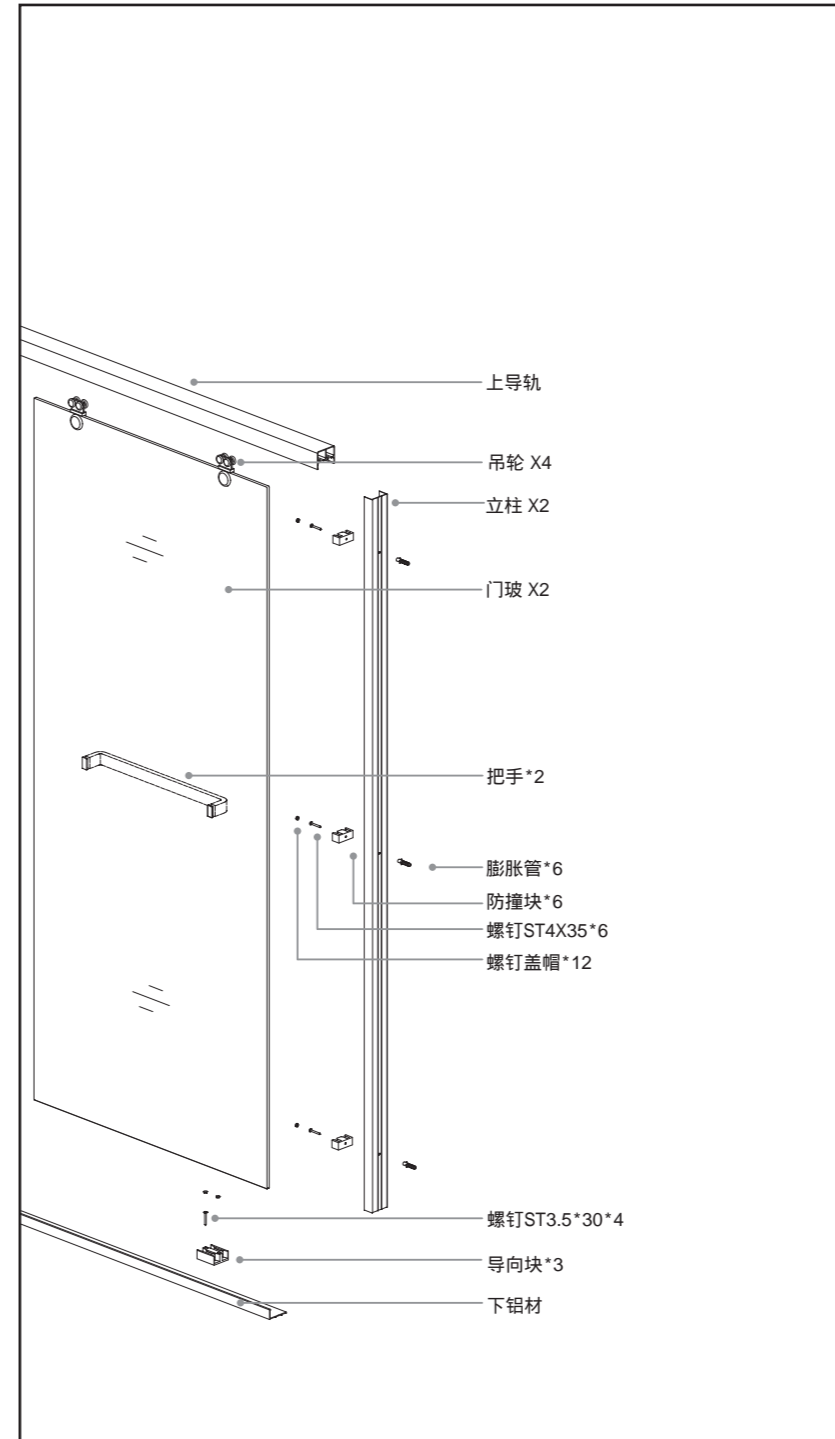
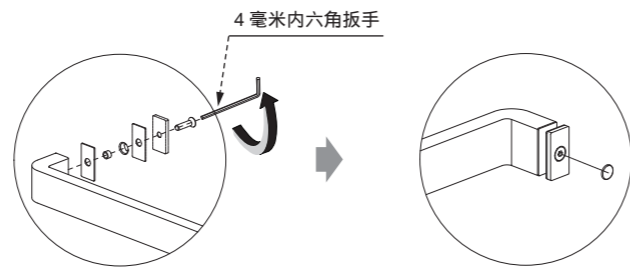
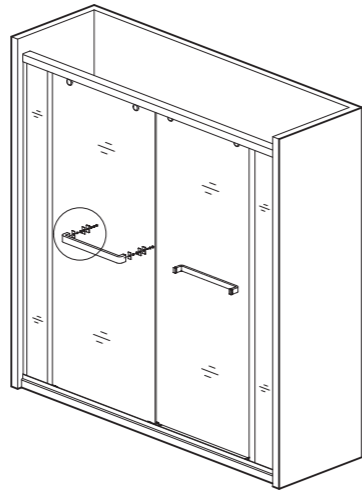

零件  
清单

# A911

五金零件清单

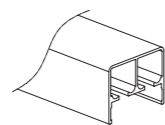

上导轨 X1



门玻 X2

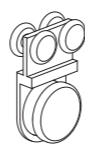

吊轮 X4

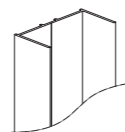

立柱 X2

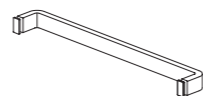

把手 X2



螺钉盖帽 X12

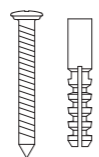

螺钉ST X 35 X 6  
膨胀管 X 6

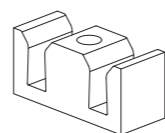

防撞块 X 6



螺钉  
ST3.5 X 30 X 4

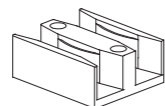

导向块 X 3

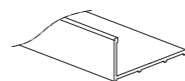

下铝材 X 1

# 09

安装门玻

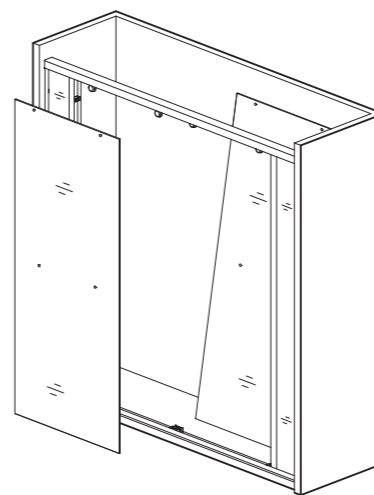

① 先将一块门玻抬进淋浴房内，斜靠在墙壁上。

- 注意：1.玻璃与地板接触要垫个纸皮；  
2.玻璃的logo从外面看是正向；  
3.下铝材上面要清理干净，不能有沙土等；  
4.吊轮的螺钉装饰盖先不要装上。

② 安装淋浴房外的这块门玻。

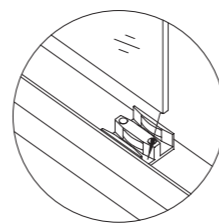

③ 将门玻放进下铝材中间位置导向块外侧的导向槽内。

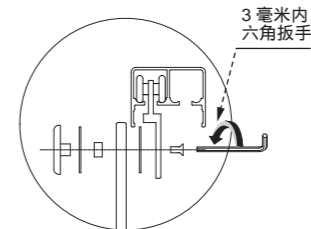

④ 将门玻锁到上导轨外侧的两个吊轮上。

⑤ 安装淋浴房内的门玻。

同理，将淋浴房内的门玻装在导向块内侧导向槽和上导轨内侧的吊轮上。

# 08

安装上导轨

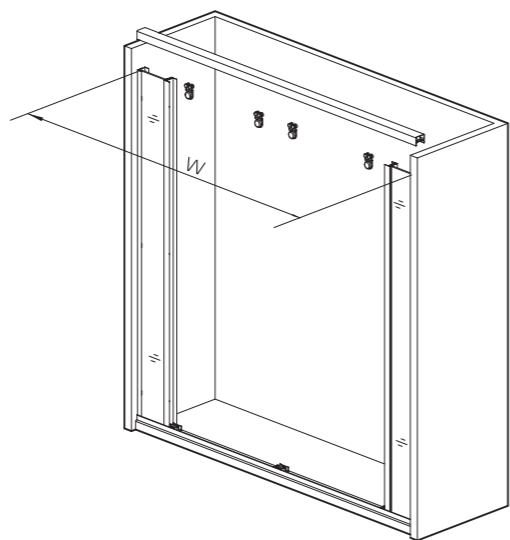

用卷尺测量淋浴房顶部的宽度W，用铝材切割机将上导轨的长度切成W。

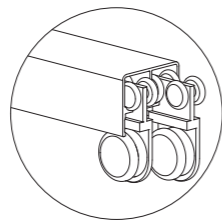

① 将四个吊轮装进上导轨

注意：四个吊轮的安装方向一致且螺钉朝内。上导轨有两个轨道，每个轨道装两个吊轮。

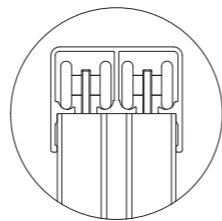

② 安装上导轨

注意：安装过程注意防止吊轮掉到地上。

## 零件清单

# A912

五金零件清单

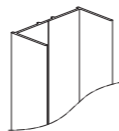

立柱 X2

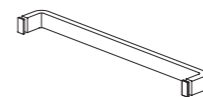

把手 X2

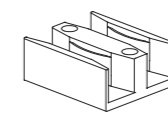

导向块 X3

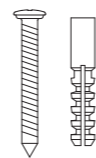

螺钉ST X 35 X 6  
膨胀管 X 6

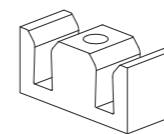

防撞块 X6

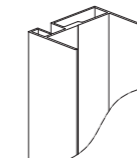

中柱组件 X1



螺钉盖帽 X12

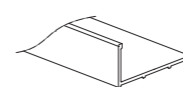

下铝材 X1

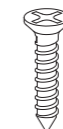

螺钉  
ST3.5 X 30 X 4

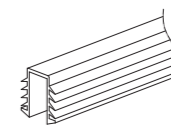

U型胶条 X1

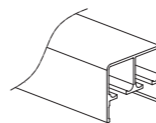

上导轨 X1

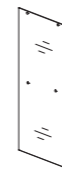

门玻 X2



固玻 X1



吊轮 X4

零件清单

A913 五金零件清单

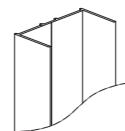

立柱 X2

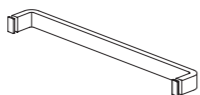

把手 X2

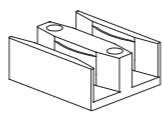

导向块 X3

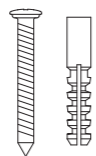

螺钉ST X 35 X 6  
膨胀管 X 6

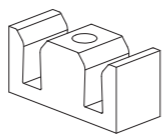

防撞块 X6

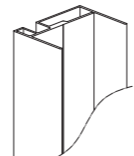

中柱组件 X2



螺钉盖帽 X12

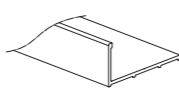

下铝材 X1



螺钉  
ST3.5 X 30 X 4

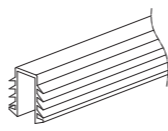

U型胶条 X2

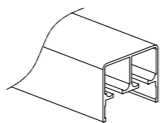

上导轨 X1



门玻 X2



固玻 X2

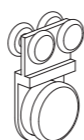

吊轮 X4

07 安装导向块

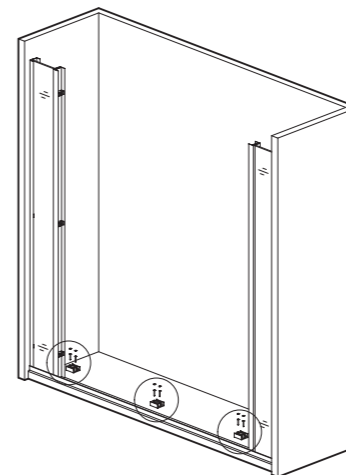

- ① 先安装左右两边的导向块  
注意：左右两边的导向块只需安装靠外面的这个螺钉。  
钻孔打在下铝材的钻孔线上。

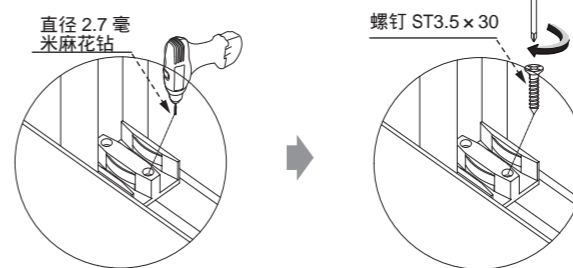

- ② 安装中间位置的导向块  
在下铝材正中间的位置安装导向块

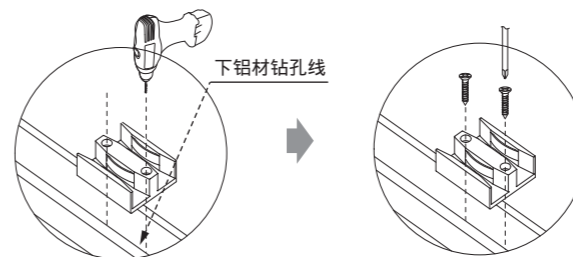



# 05

## 确认产品的 安装方式

- 1.如果您购买的单品型号为A911，只有两块门玻，请跳过以下安装固定玻璃的步骤。
- 2.如果您购买的单品型号为A912，有两块门玻和一块固定玻璃，请先确认固定玻璃是安装在左边还是右边；固定玻璃的安装方式请参照A913。
- 3.如果您购买的单品型号为A913，有两块门玻和两块固定玻璃，请按以下步骤安装。

# 06

## 安装固定玻璃

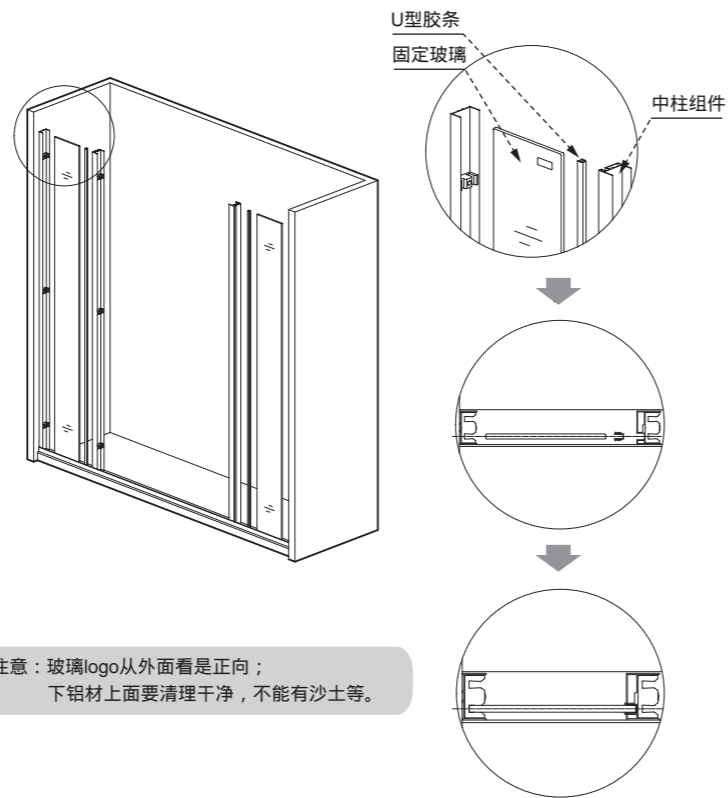

注意：玻璃logo从外面看是正向；  
下铝材上面要清理干净，不能有沙土等。

## 安装 准备

### 敬告：

安装前，务必仔细阅读本安装使用说明书的全部内容！本说明书适用A911、A912、A913三款一字型淋浴房产品。

### 安装注意事项

#### 1.本产品安装范围：

A911 - 安装宽度1400-1600mm，高度2100mm以上；

A912 - 安装宽度1600-1800mm，高度2100mm以上；固定玻璃可安装在左边或右边，安装前请先确认；

A913 - 安装宽度1800-2000mm，高度2100mm以上。

2.安装前，请确认安装位置地面上有挡水石且挡水石内外都有地漏。

3.安装前，请确认您家单面墙倾斜度不超过10mm，即两面墙壁底部宽度和2米高处的宽度差不超过20mm。

4.安装过程中，请佩戴手套和防护眼镜。

5.在墙上钻任何孔时，请确保钻孔的地方没有隐蔽的管道和电缆。

6.清点物料时，请不要先把玻璃抬出纸箱。

7.抬玻璃时需要特别注意，不要让玻璃的边角碰到地板或墙壁。

8.使用电钻在瓷砖上钻孔时，先将电钻调到平钻档，钻透瓷砖后再调到冲击档。

9.尽量使用手动螺丝刀锁螺钉，如果使用电动螺丝刀，请先把扭力调到最大值的一半，再按需求逐级增加。

10.安装过程中如有疑问请联系SOLUX售后服务电话：400-667-6665

# 安装准备

## 自备安装工具



## SOLUX配备的安装工具

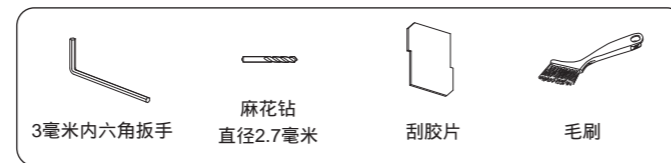

# 04 安装立柱和防撞块

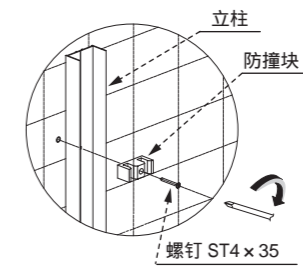
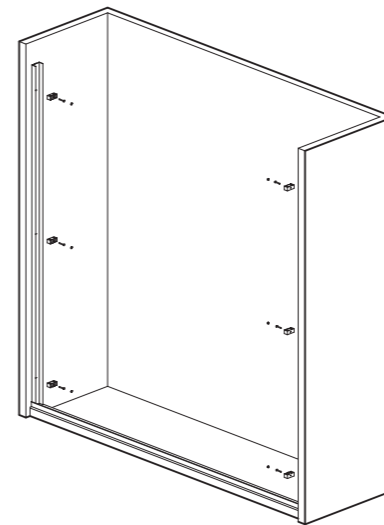

① 安装立柱和防撞块  
注意：保证立柱垂直

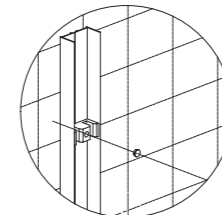

② 安装螺钉盖帽

# 03

## 墙壁钻孔和装膨胀管

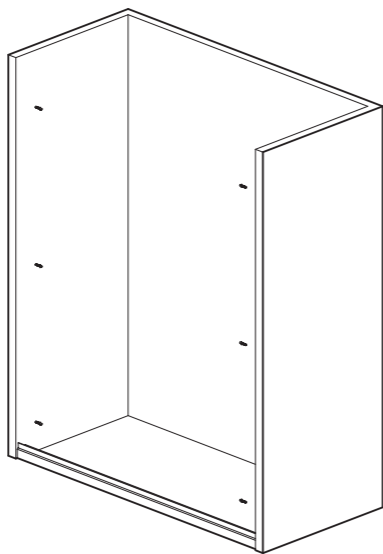

直径 6 毫米冲击钻头

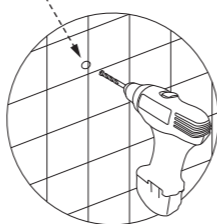

① 用冲击钻在两边  
墙壁上画点处钻孔

注意：钻孔深度为  
35-40 毫米

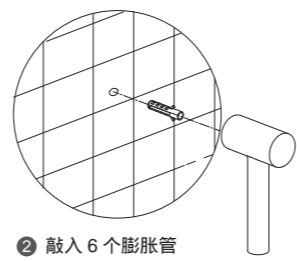

② 敲入 6 个膨胀管

注意：膨胀管不能凸出来

## 安装 步骤

### 1 视频安装攻略



二维码

### 2 图文安装攻略

# 01

切割和放置下铝材

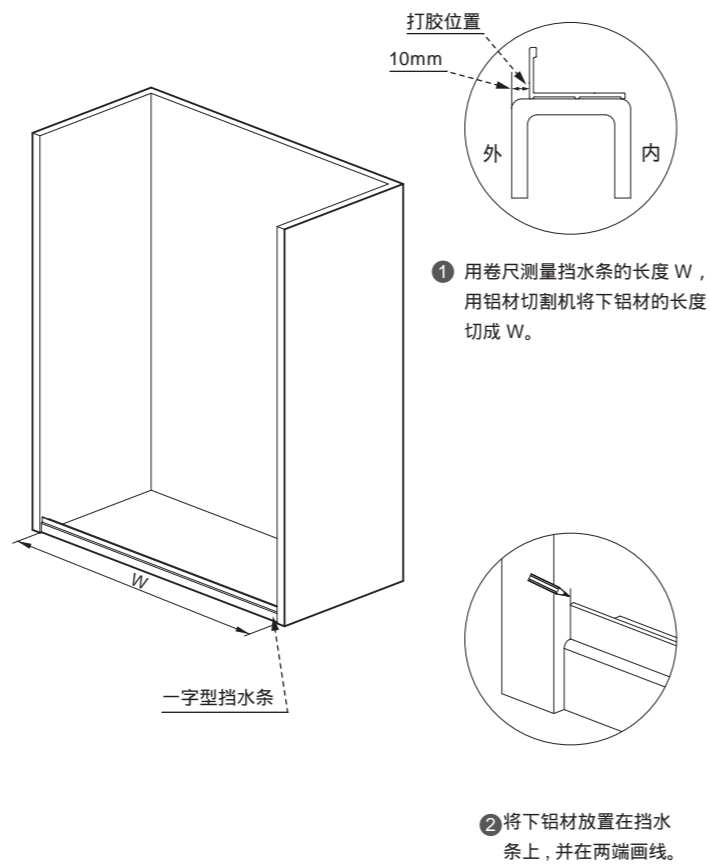

# 02

墙壁画线

将两根立柱分别放置在下铝材的上面，并贴紧墙面，保持垂直，在墙壁上画点。

